

# Extension of the image model to arbitrary polyhedra

Jeffrey Borish

Center for Computer Research in Music and Acoustics, Stanford University, Stanford, California 94305

(Received 12 November 1982; accepted for publication 1 March 1984)

In this paper, the image model is extended to arbitrary polyhedra with any number of sides. This generalization makes it possible to model real concert halls much more accurately. The image positions computed by the method can be reduced to the directional impulse response in order to create audible simulations of the concert hall. Also, the image model can provide insight into the fundamental acoustical properties of different concert hall geometries. For example, the extended image model demonstrates that rectangular halls have an advantage over fan-shaped halls with regard to spatial impression. We also show why the image model has fundamental advantages over another popular modeling technique, ray tracing.

PACS numbers: 43.55.Ka

## INTRODUCTION

The image model is a technique that is widely known for analyzing the acoustical properties of a space that includes reflecting boundaries.<sup>1,2</sup> The method of images makes it possible to represent a boundary-value problem in terms of an equivalent problem involving multiple sources, but no boundaries. Implementation on a digital computer has led to some new applications for the image model. Gibbs and Jones<sup>3</sup> used the image model to estimate the total sound intensity in a concert hall. More recently, Allen and Berkley<sup>4</sup> presented a method for creating synthetic reverberation based on the image model. Their efforts were directed specifically toward developing a method that was efficient and easy to use. To accomplish this goal, they restricted the model to rectangular enclosures. Although attempts have been made to generalize to more complex geometries, usually some restrictions have remained. Barron<sup>5</sup> limited his model to two reflections and retained some geometrical restrictions. Baxa<sup>6</sup> was limited by core size to five reflections. His algorithm is similar to ours, but our technique is able, even with modest memory sizes, to compute the positions of images up to essentially any number of reflections. Although simple models have the undeniable advantage of being comparatively simple to apply and of requiring less computation time, they are rarely representative of situations one encounters in reality. Most concert halls are very irregularly shaped, so when one is interested in modeling their characteristics more faithfully, it is important to have an algorithm that is sufficiently general.

Any reasonable assumptions for the shape of a concert hall will always involve simplifications at some scale. Boston's Symphony Hall is one that is generally regarded as being rectangular, but of course its ceiling is coffered, the walls have alcoves with statues, and the floor has seats with people. It would be impossible to account for every door-knob and every light bulb in the hall. But even when consideration is restricted to the macroscopic geometry, it would be useful to generalize the image model. Symphony Hall has angled reflecting surfaces around the stage that probably have a significant effect upon the sound reaching frontal locations. Other halls deviate even more dramatically from the

ideal rectangular shape, such as fan- or horseshoe-shaped halls. Also, most halls have balconies that obstruct a significant portion of the sound directed toward seats underneath them. This paper shows how the image model can be generalized to deal with all of these situations. The only constraint on the degree of complexity is the amount of time required for the computations.

## I. THE ALGORITHM

In this section we describe the algorithm for computing the image positions in a polyhedron with an arbitrary shape. The basic principle of the image model is that a path involving reflections can be represented by a straight line path connecting the listener to a corresponding virtual source (VS). When this idea is applied to a rectangular room, a regular lattice of VSs results (Fig. 1). Because of the regularity of this lattice, the calculation of the VS positions is trivial.<sup>3,4</sup> For irregular shapes it is more difficult to find the positions. Moreover, it is necessary to consider in irregular shapes that a VS might not be "visible" from every position in the room (Fig. 2). Applying the image model to irregular shapes not only involves a more complicated procedure for finding the

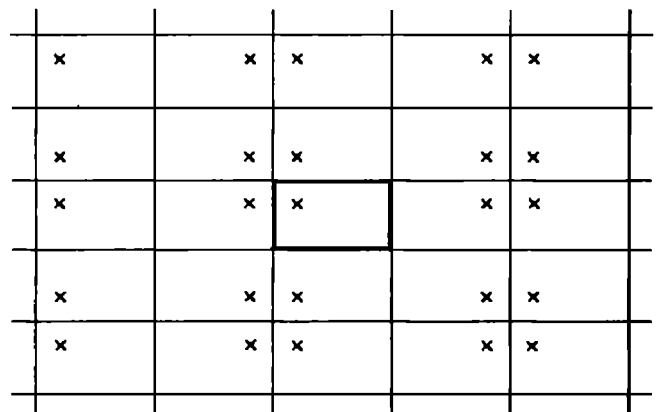

FIG. 1. For a rectangular room, the lattice of VSs is very regular making it easy to compute their coordinates. The accentuated box in the center represents the real room, and surrounding it are the virtual rooms each containing a single VS.

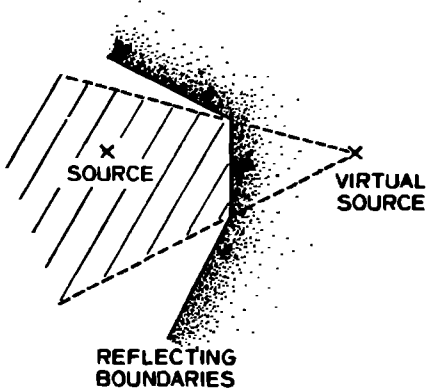

FIG. 2. The listener must be in the shaded region for the virtual source to be visible.

positions of the VSs, but a visibility test must be performed to determine which VSs are visible.

### A. Finding the image point

Given a reflecting surface with an arbitrary orientation and a source point, we need to find an expression for the position of the image point. The position and orientation of the plane of the reflecting surface are described by two parameters, the unit normal to the plane  $\hat{n}$ , and the distance from the origin to the plane  $p$ . Referring to Fig. 3, the image point can be found by traveling from the real point a distance  $2d$  in the direction of the planar normal.  $d$ , the distance from the point to the plane, is given by

$$d = p - \mathbf{P} \cdot \hat{n}, \quad (1)$$

so that  $\mathbf{R}$ , the position vector of the image point, is

$$\mathbf{R} = \mathbf{P} + 2d\hat{n}. \quad (2)$$

Finding the image point requires seven additions and six multiplications, compared to only one addition for the rectangular lattice of Fig. 1. The general algorithm will clearly require a great deal more computation.

### B. Generating the lattice of virtual sources

Now that we have a means for finding the position of the image of a point in a reflecting boundary, we need a way of applying this operation systematically to assure that every VS is found. The basic concept of the algorithm is very simple: reflect every VS across every reflecting surface. This algorithm is recursive because reflecting a VS across a boundary will produce a new VS which in turn must be reflected across every boundary. Calculating the VS positions can be represented by a tree. The nodes in the tree represent the VSs, and the branches are formed when a VS is reflected across a boundary. The order of a VS indicates the number of reflections that were required to create it. The VSs created by reflecting across the sides of the polyhedron are called the progeny VSs.

Each VS created must be qualified by three criteria. The first is called validity. By considering the boundaries of the polyhedron to be mirrors with the reflective sides facing into the room, an invalid VS can be defined to be one created by reflecting across the nonreflective side of the boundary. The most straightforward way this problem can arise is to reflect a VS back across the same side used to create it. This particular situation could be easily avoided by remembering which side was used to create a VS, and then skipping this side when the VS is propagated. However, it is also possible for invalid reflections to arise from more complicated routes, such as the one shown in Fig. 4. One solution to this problem is to test explicitly for validity each time a VS is created. Invalid reflections can be detected very easily as part of the computation of the position of the progeny VS. If the distance computed in Eq. (1) is negative, then the reflection is invalid. Otherwise, qualification continues to the second step.

The second criterion that a VS must satisfy is proximity. The user of the program inputs a distance. VSs farther from the listener than this distance are discarded and the line of descent is terminated. It is impossible for its progeny to be closer to the listener. The proximity criterion is what makes

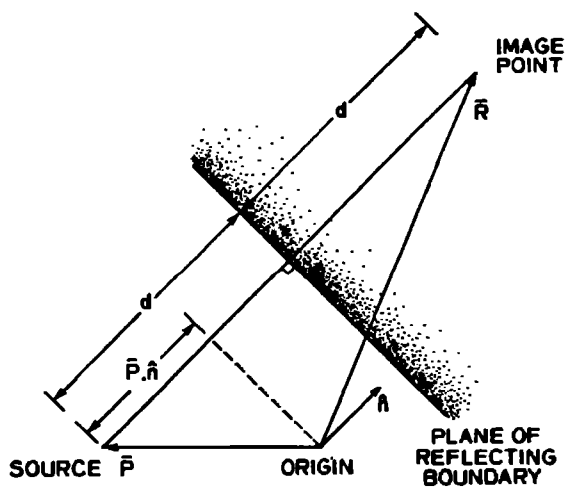

FIG. 3. Diagram showing how to determine the position of the image point. Its coordinates are found by traveling from the real point a distance of  $2d$  in the direction of the normal.

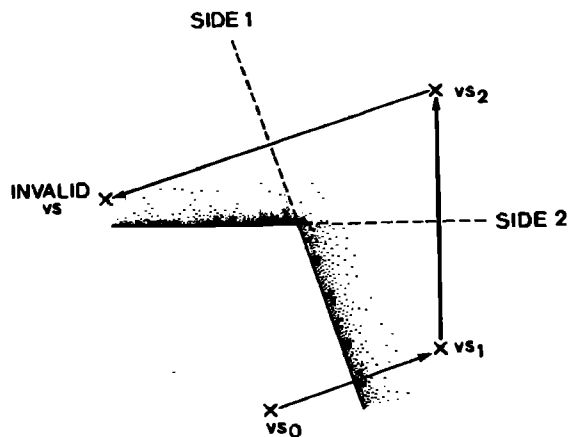

FIG. 4. When  $vs_1$  is reflected across side 1, or  $vs_2$  is reflected across side 2, invalid VSs are created. These cases could be avoided by not reflecting a VS across the side used to create it. However, it is also possible for an invalid VS to be created by routes not easily anticipated. These cases must be detected by an explicit test.

it possible for the algorithm to terminate. Although it would be possible to terminate the propagation on the basis of another criterion, e.g., by finding all VSs up to some order, proximity is the one that assures that every sound path shorter than a selected maximum will be found. This completeness is important for accurately characterizing the behavior of a room within a certain period.

The third criterion a new VS must satisfy is visibility. The visibility test is the most involved by far. In general, it must be performed in several steps. The first step is always to ascertain that the progeny VS is visible to the listener in the

side that created it. As shown in Fig. 2, when obtuse angles are allowed it is possible that the listener will not be able to "see" the progeny VS.

To test for visibility, a line is formed joining the new VS with the listener, and the point of intersection of this line with the plane of the reflecting side is determined. If the point lies inside the boundary of the side, the VS is visible. There are many ways of testing whether the intersection is inside the boundary. One straightforward method is to form vectors from the point of intersection to each of the vertices of the side. The cross products of successive pairs of these vectors are always a vector orthogonal to the plane of the side. If each of the normal vectors so calculated points to the same side of the reflecting boundary, then the point of intersection is inside the polygon. Otherwise it is outside, and the VS is not visible. Figure 5 illustrates these two possibilities. The algorithm can be explained heuristically by imagining one is standing at the point of intersection looking at each vertex in turn. As long as viewing successive vertices requires rotation in the same direction, one is inside. Having to reverse one's direction of rotation indicates the point is outside.

In practice, the vectors from the point of intersection to the vertices are formed as they are needed for calculating the cross product. As soon as a cross product is calculated that points in the direction opposite to previous ones, the test is terminated. Only when the point is inside the periphery is it necessary to carry the test to completion. As a result, tests that fail are on the average half as long as tests that pass. The cross product requires six multiplications, so the number of multiplications required by the algorithm is no more than  $6v$ , where  $v$  is the number of vertices on the side.

For first-order reflections this test is sufficient. Higher-order reflections require additional visibility tests. Consider the second-order reflection in Fig. 6. By decomposing the path from the VS to the listener into the actual path the sound travels, it is clear that if side 2 extends to point A the path will exist, but if it extends only to point B the path will not exist. An additional visibility test is necessary to validate segment a-b. This test can be performed by looking for  $vs_1$  in side 2 from the position that is the mirror image of the real listener position. Paths involving more reflections require higher-order virtual listeners that look for corresponding VSs in order to validate every segment of the real sound path.

Only VSs that are visible contribute to the sound that reaches the listener. However, VSs that are not visible are retained because their progeny might still be visible. A VS is discarded only when it fails either of the first two tests, proximity or validity.

The number of VSs at each level of the tree increases rapidly. The number of VSs at level  $k$  is approximately  $N^k$ , where  $N$  is the number of sides in the polyhedron. This expression is only approximate because not every VS survives the first two qualifying tests. Because the number of VSs increases so rapidly, remembering all of them at the same time would require an excessive amount of storage. The visible VSs usually represent a small part of the complete set of VSs. The invisible VSs need to be remembered only temporarily until all their descendants have been found.

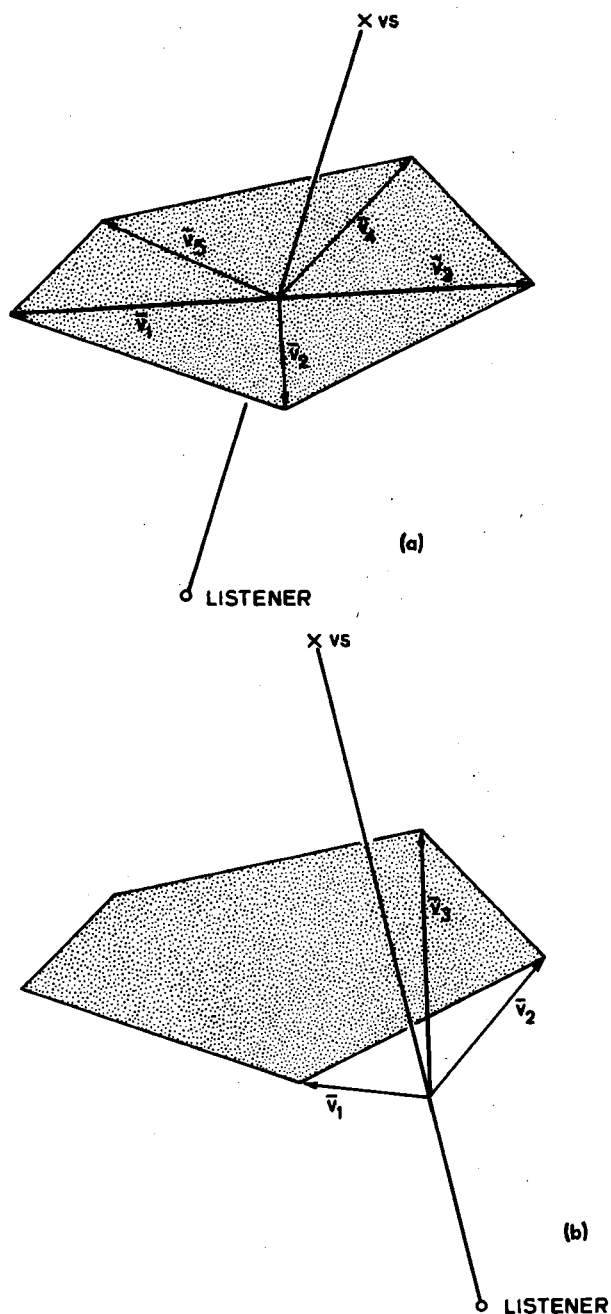

FIG. 5. The test to determine whether the point of intersection is inside the boundary of the side is performed by computing the crossproducts of the vectors from the point of intersection to each of the vertices in turn. In (a), all of the crossproducts point up, so the point is inside the boundary. In (b),  $v_1 \times v_2$  points down, but  $v_2 \times v_3$  points up, so the point is outside.

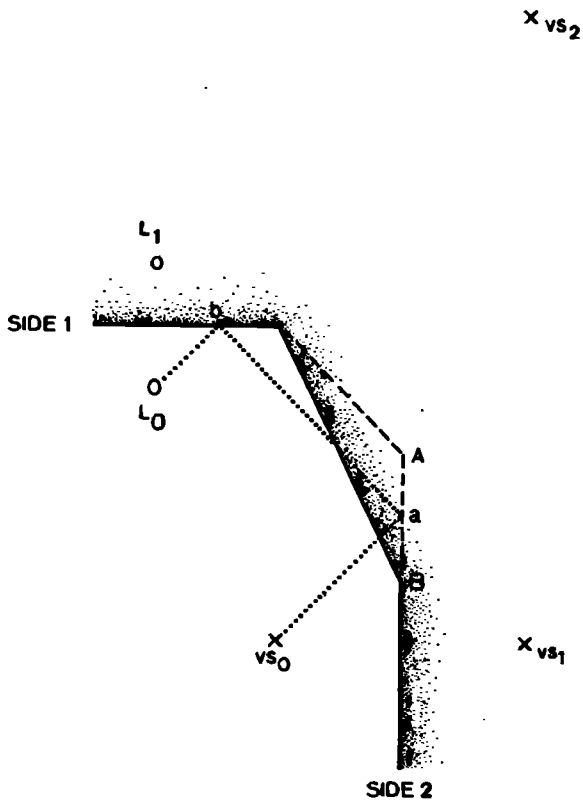

FIG. 6. Although  $vs_2$  is visible in side 1 from the listener position,  $vs_2$  still will not be visible if side 2 extends only to point B. Validating segment a-b of the sound path requires that virtual listener  $L_1$  look for  $vs_1$  in side 2.  $L_1$  will not see  $vs_1$  if side 2 ends at B.

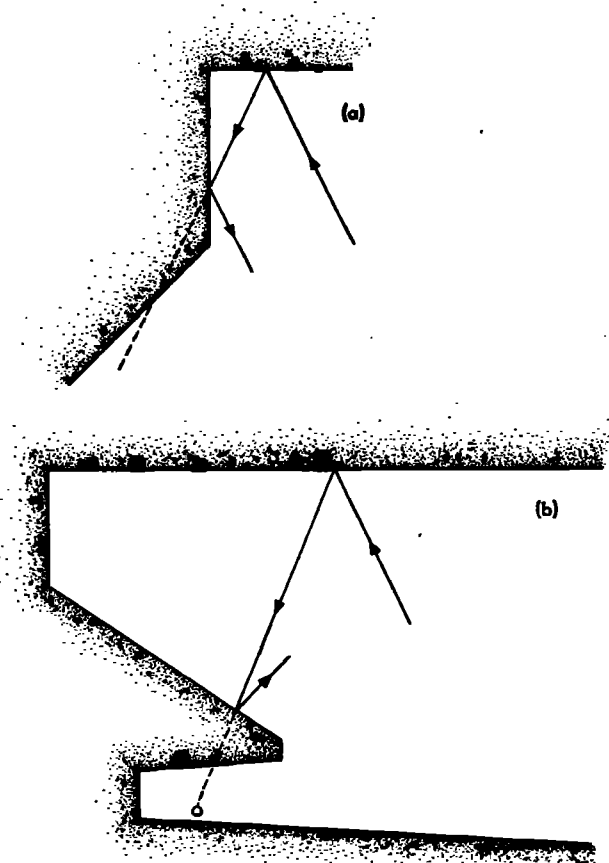

FIG. 7. In (a), an obstruction is formed by a splay in a side wall, (b) illustrates the familiar case of a balcony obstructing a sound.

By traversing the tree using a preorder sequence<sup>7</sup> rather than on a level-to-level basis, only the VSs in a direct line of descent need to be stored. Simulations rarely exceed eighth order, so the memory requirements can be vastly reduced. When a VS is visible, it is placed in a separate table of visible VSs. Otherwise it is forgotten as soon as it is no longer needed to propagate the tree.

### C. Obstructions

All the discussion to this point has assumed the polyhedron to be convex. Allowing re-entrant angles makes it possible for a sound path to be obstructed. A side that has the potential of obstructing a sound is designated obstructive. Most, if not all, concert halls have obstructive sides. The obstructor might be as innocuous as a wall that splays outward, or it could be a balcony (Fig. 7). Because obstructive surfaces are so common, it is important that the image model be able to deal with them. Testing for obstructions must be performed for each segment of the path, just as for visibility testing. The point of intersection of the line connecting the test VS and test virtual listener with the plane of each potentially obstructive side is calculated. If the intersection is inside the boundary of the side, then the view is obstructed. Because obstruction testing adds a considerable burden to the visibility test, obstructive sides are tagged so that the test will not be applied to sides that cannot obstruct the sound. Obstructive sides are treated normally as far as reflections are concerned. Thus a balcony can also produce

reflections, as shown in the figure.

Testing whether the point of intersection is inside the boundary of the side is more complicated when re-entrant angles are allowed. As seen in Fig. 8, the direction of rotation can reverse even when the point is inside the boundary. The solution is to sum the angles of rotation in moving from one vertex to the next. If the total is  $2\pi$  rad the point is inside. If it is 0 the point is outside.

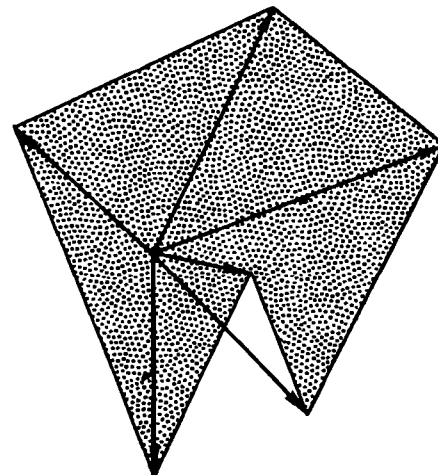

FIG. 8. When re-entrant angles are allowed, the direction of rotation can reverse even when the point is inside the boundary. Therefore the test must measure the total rotation.  $2\pi$  rad indicates the point is inside; 0 rad indicates it is outside.

TABLE I. The notional computer program for the extended image model. Each valid and proximate VS is recursively propagated. Only visible ones are remembered.

```

RECURSIVE PROCEDURE propagate (vs);
BEGIN "propagate"
  FOR side←-1 STEP 1 UNTIL nsides DO
    BEGIN "reflect vs across each side"
      progeny_vs←-reflection (vs, side);
      IF NOT valid (progeny_vs) THEN CONTINUE "reflect vs across each side";
      IF NOT proximate (progeny_vs) THEN CONTINUE "reflect vs across each side";
      IF visible (progeny_vs) THEN
        IF NOT obstructed (progeny_vs) THEN
          remember (progeny_vs);
          propagate (progeny_vs);
        END "reflect vs across each side";
      END "propagate";
    END "propagate";
  END "propagate";

```

The complexity of the testing that must be performed increases as the interior angles of the polyhedron are allowed to increase. An acute polyhedron (one whose interior angles are no greater than 90°) does not require visibility testing. A concave polyhedron (one whose interior angles are no greater than 180°) does not require obstruction testing. The

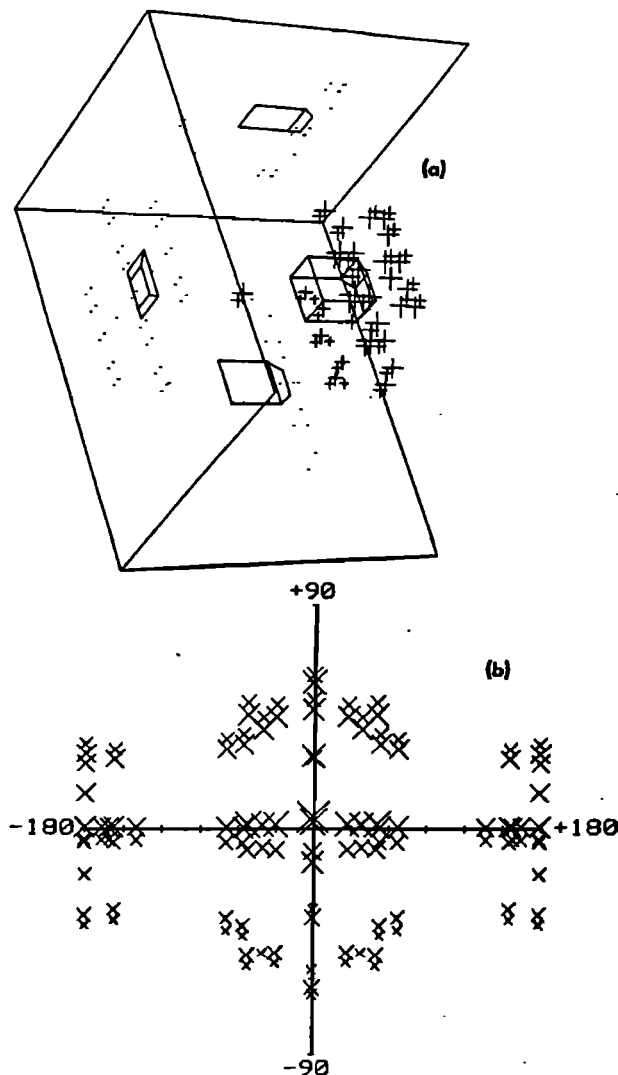

worst case is a polyhedron with re-entrant angles, which requires both visibility and obstruction testing.

The extended algorithm is summarized by the notional computer program in Table I. The procedure that generates the tree, called PROPAGATE, is recursive. The program is initiated by calling PROPAGATE with the coordinates of the real source. The functions of the subroutines should be clear from the preceding discussion. Whenever a valid and proximate VS is found, the procedure invokes itself with the new VS. Consequently, the tree traversal proceeds to the tips before completing the propagation at any one level.

## II. USING THE RESULTS

In this section we show how the extended image model can be used to analyze and simulate concert hall geometries.

### A. Displaying the results

Because of the three-dimensional character of the data produced by the image model, displaying the results in a meaningful manner requires some consideration. The most straightforward presentation is a perspective view of the three-dimensional scene made up of the concert hall, the source, and the surrounding VSs [Fig. 9(a)]. Also in this dis-

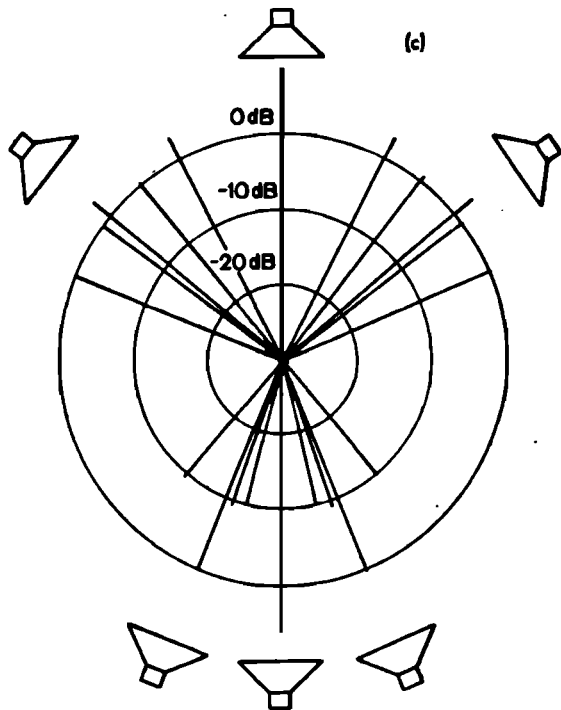

FIG. 9. Three different techniques for displaying the positions of the VSs. (a) is a perspective view of the concert hall with its VSs. (b) shows the positions of the VSs in the angle plane, with the size of the X indicating the strength of the VS. Finally, (c) is a polar plot of sound power as a function of azimuth (the elevation is ignored). All the displays are based upon an idealization of Symphony Hall.

play are three imaginary walls upon which are drawn the projections of the three-dimensional scene along each of the coordinate axes. The user is able to change his vantage. It is also possible to view only the projections on the imaginary walls.

Another type of display is illustrated in Fig. 9(b). This display shows the positions of the VSs in the "angle plane." The vertical axis is the elevational angle, and the horizontal axis is the azimuthal angle. The size of the  $\times$  indicating the position of a VS can be used to suggest either its distance from the listener or the amplitude of its sound. This type of plot is very useful for displaying the diversity of directions from which sounds emanate. Some concert hall geometries tend to compress the VSs into smaller regions; others scatter them about more uniformly.

A third type of display is a polar plot of sound power [Fig. 9(c)]. This display gives a very clear indication of the extent sound is spread to the sides. In the polar plot, as in the angle plane,  $0^\circ$  azimuth is defined as the direction of the source. We will find different circumstances in which each is the most appropriate presentation.

## B. Calculating the directional impulse response

The primary application of the image model is creating audible simulations of concert halls. To create the impression that the sound was produced in a physical realization of the hall, a dry audio signal must be convolved with the impulse response of the hall. Reducing the VS positions to the impulse response is straightforward. The distance between the source and listener produces a delay of

$$t_0 = \|\mathbf{vs}_0 - \mathbf{l}\|/c, \quad (3)$$

where the vectors  $\mathbf{vs}_0$  and  $\mathbf{l}$  represent the source and listener positions, and  $c$  is the speed of sound. It is impossible for a listener to detect this delay time using only his auditory sense, so the arrival times of all the echoes are referenced to the arrival time of the direct sound:

$$\tau_i = \|\mathbf{vs}_i - \mathbf{l}\|/c - t_0, \quad i > 0, \quad (4)$$

where  $\mathbf{vs}_i$  is the vector to the  $i$ th VS.

Having found the arrival times of the delayed sounds, one must next determine their amplitudes. It is conventional in the image method to consider the attenuation as arising from two factors. First, the sound pressure level depends upon the reciprocal of the distance traveled because the sound, assumed to have been produced by a point source, propagates in a spherical wave. Second, sound energy is absorbed at the reflecting boundaries. Thus the amplitude of a delayed sound relative to the direct sound is given by

$$g_i = \frac{R_0}{R_i} \prod_{j \in S} \Gamma_j, \quad (5)$$

where  $R_i$  is the distance of the listener from the  $i$ th VS,  $S$  is the set of sides the sound encounters, and  $\Gamma_j$  is the reflection coefficient of the  $j$ th side. It is also possible to include an exponential term to model the distributed absorption by the air itself.<sup>3</sup>

In presenting the simulated reverberation to a listener, it is important that some means be found for conveying the directional dependence of the impulse response. The posi-

tion of a VS relative to the listener indicates the direction from which its sound will reach the listener. The most precise presentation is obtained by positioning speakers around the periphery of the room in directions corresponding to the directions of the virtual sources. The angle plane plot [Fig. 9(b)] gives a clear indication of the directions that are required. The signal that drives each speaker must be delayed and attenuated appropriately to account for the distance between the speaker position and the position of the corresponding virtual source. Clearly, the large number of speakers required makes this approach impractical, although it is precise.

Several levels of approximation are available depending upon the degree of precision that is desired. The first level of approximation ignores the elevational component of the virtual source positions. The rationale for this step is that our hearing is less sensitive to a vertical displacement of a sound than to a lateral displacement. The polar plot that we considered earlier [Fig. 9(c)] is the appropriate presentation now. We can see in this plot that the number of directions is still fairly high. However, we can also see that the sounds tend to group together into bands of directions. Because of the limited directional acuity of our hearing, it is usually reasonable to present all of the sounds within each of these bands with a single speaker positioned at the "average" direction. Using this approach, the Symphony Hall model requires only six speakers. No minimal speaker placement will be appropriate for every simulation. Using the image model makes it possible to optimize the configuration for the particular concert hall being simulated and for the degree of precision that is desired.

## C. Influence of concert hall geometry upon subjective response

In addition to providing a means for determining the impulse response of a concert hall, the image model is also capable of providing insight into ways in which the concert hall geometry affects our subjective response. Many of the concert halls widely regarded as the best in the world are rectangularly shaped. Other commonly used shapes, such as the fan shape, have rarely been found to provide the same degree of listener satisfaction. Although it is conceivable that the differences are coincidental—having to do with the particular implementations, choice of materials, etc.—the consistency of the differences strongly suggests that a fundamental law is at work.

To approach this problem using the image model, displays were generated for a sequence of concert halls that vary from a fan-shaped hall, to a rectangularly shaped hall, and finally to a reverse fan. Viewing the VS positions from directly above to suppress the elevational component (Fig. 10), we observe an interesting progression in the VS pattern. For the rectangularly shaped hall, the VSs spread out to the side in straight lines, as expected. Because the computation of VS positions is terminated on the basis of their distance from the listener, only the beginning of the regular pattern is visible. When the side walls are splayed outward in the fan-shaped hall, the lines of VSs curve toward the front of the hall. Conversely, when the side walls splay inward in the reverse fan,

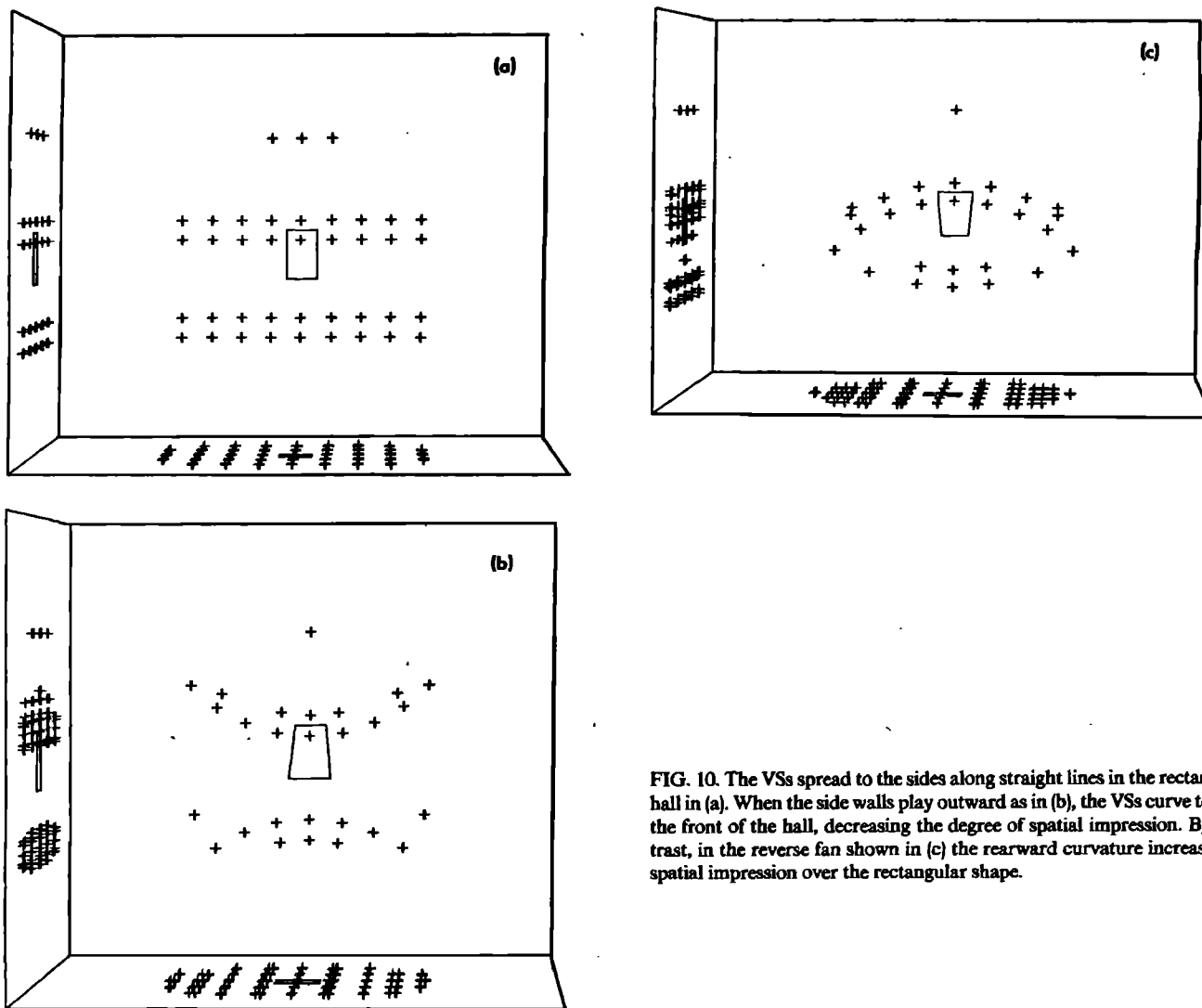

FIG. 10. The VSs spread to the sides along straight lines in the rectangular hall in (a). When the side walls play outward as in (b), the VSs curve toward the front of the hall, decreasing the degree of spatial impression. By contrast, in the reverse fan shown in (c) the rearward curvature increases the spatial impression over the rectangular shape.

the VSs curve rearward. From the listener's perspective, the fan shape compresses the sound toward the center whereas the reverse fan spreads it to the sides, a fact which is emphasized in the polar plots for the same sequence of halls (Fig. 11). Barron<sup>5</sup> has described the subjective effect of lateral de-

layed sounds as spatial impression (SI). The farther from the median plane, the greater the SI. Of the the three hall shapes examined, the fan-shaped hall would show the lowest degree of SI. The rectangular hall would be expected to be preferable, as is often found to be the case in practice. What is some-

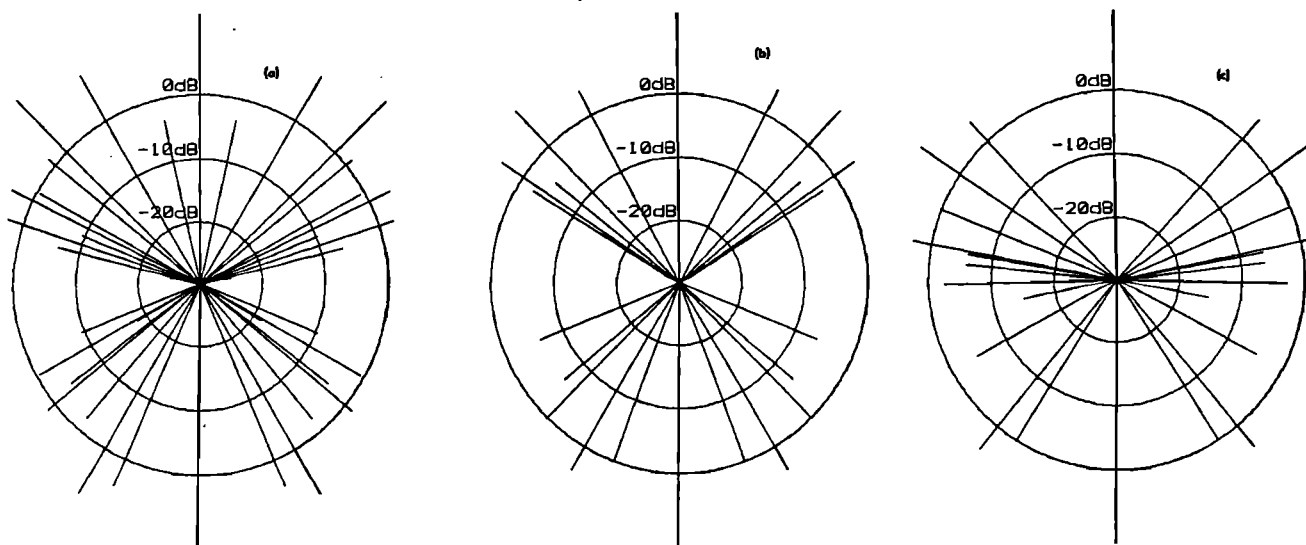

FIG. 11. The polar plots for the same sequence of halls from (a) rectangular to (b) fan to (c) reverse fan emphasize that the lateral sound is more centralized in the fan hall and less in the reverse fan than the rectangular hall.

what unexpected is that the sequence continues to the reverse fan which should be the best of the three. This shape has never been applied in an actual concert hall.

The reason the reverse fan-shaped hall has never been attempted in practice presumably has to do with its practical limitations. One of the economic pressures in designing new concert halls is to increase the seating capacity. The fan shape is a natural outgrowth of this desire as it provides a large number of seats with acceptable sightlines. Because the width of the front part of the concert hall is constrained by the requirements of the performing groups, the reverse fan would sacrifice seating capacity. Furthermore, the reverse splay of the side walls would probably create some problems in the appearance of the hall. One way it might be possible to combine the acoustical advantages of the reverse fan with the practical advantages of the fan would be to segment the walls. The orientation of the segments would correspond to the reverse fan, but their positioning would provide an overall fan shape [Fig. 12(a)]. As shown in Fig. 12(b), the VSs show the same tendency as in the reverse fan to curve toward the rear, so the reverse fan and the segmented fan should have comparable SI. Ironically, segmentation of the walls is often applied in concert hall designs, but invariably the ori-

entation is chosen to simulate a fan with a larger splay. The resulting central compression of the VSs is exactly the opposite of what is required to increase SI. It is intriguing to consider how the acoustics of the hall could be adjusted if these panels were allowed to rotate. By changing the degree of SI, this adjustment might provide a more meaningful control of the acoustics of a concert hall than techniques currently in vogue.

Many studies of the acoustical implications of concert hall geometry consider only first- or second-order reflections, obviating computer modeling. The comparison in this section illustrates how important it is to consider higher-order VSs as well: detecting differences on the basis of only the first-order reflections would have been difficult although the differences are apparent when higher-order VSs are considered. Thus computer modeling is a useful tool in analytical studies of concert hall design as well as in the creation of audible simulations.

#### D. Ray tracing

The image model is also useful for analyzing the characteristics of another technique often used for computing sound paths in a concert hall, ray tracing.<sup>8-10</sup> Ray tracing is a more popular technique for analyzing the sound paths in a concert hall because it tends to be easier to program than the image model, particularly for complex geometries. If it were possible for the two techniques to deal with an infinite computation, then they would produce identical results. Differences arise as a result of the different ways the methods restrict their computation to a finite size. The ray tracing method limits its computation by assuming that the source emits a finite number of rays uniformly distributed over direction. As a result, the ray tracing method will always find a certain number of sound paths, but they will not necessarily be a complete set of the sound paths within the time interval spanned. In the ray tracing method, each ray is extended by means of linear extrapolation and specular reflection until it reaches a zone of space surrounding the listener. We can analyze the behavior of the ray tracing method by using the ideas of the image model itself. Accordingly, a simple path involving a single reflection can equivalently be represented as a straight line path connecting the source to a virtual listener located in an adjacent virtual room. Once again, when we extend this idea we obtain a lattice of virtual rooms surrounding the real room (Fig. 13), but this lattice is the dual of the lattice in Fig. 1 because now each virtual room contains a virtual listener rather than a virtual source. Each of the paths that the ray tracing method finds in the real room can be unfolded into a straight line path connecting the source to one of the virtual listeners in the lattice. As usual, the image model simplifies our analysis by allowing us to consider straight line paths instead of paths involving reflections.

This figure illustrates the two principal problems that can arise in the ray tracing method. The first problem is that farther virtual listeners can be hidden behind closer ones. When the ray labeled  $\alpha$  is emitted by the source, it travels a short distance before it finds a virtual listener located in a room only two rooms removed from its point of origin. At this point, the usual practice is to discontinue the extension

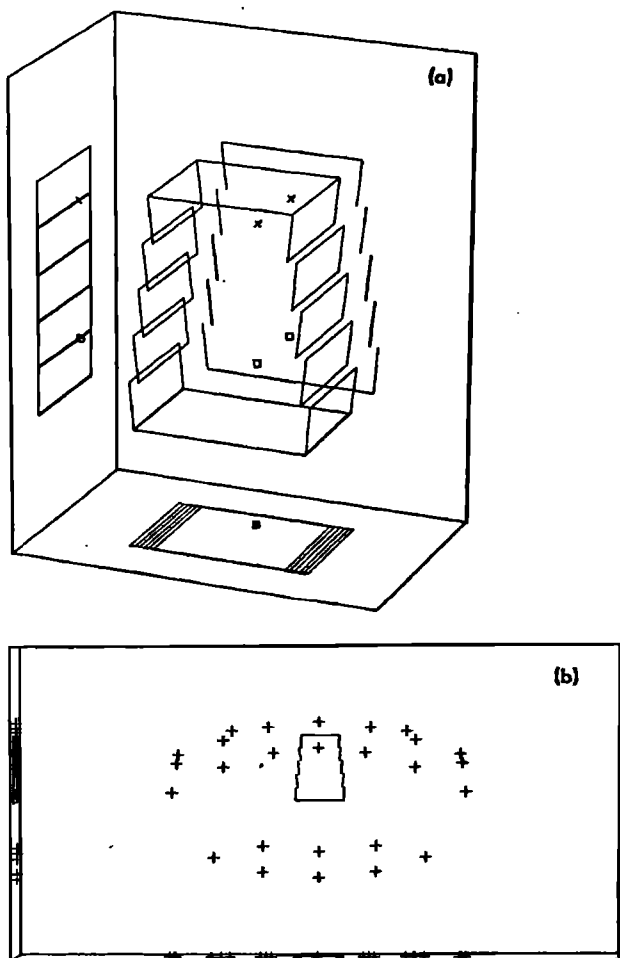

FIG. 12. A practical way of combining the acoustical characteristics of the reverse fan with the practical advantages of the fan shape is to segment the side walls, and orient the segments in correspondence to the reverse fan. As shown in (b), the VS positions show the same rearward curvature as in the reverse fan.



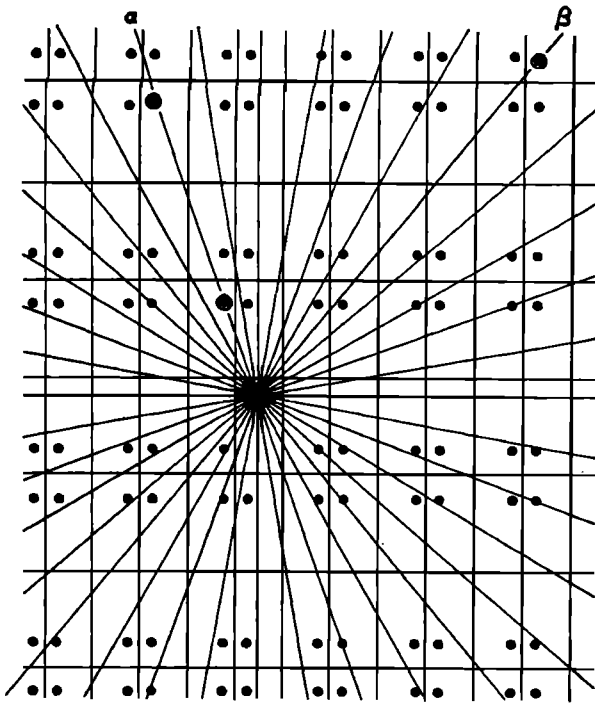

FIG. 13. In the ray tracing method, the rays emitted by the source are extended until they find a virtual listener. Ray  $\alpha$  misses the second virtual listener that is hiding in the shadow of the closer one. Ray  $\beta$  finds a virtual listener near the periphery of the display, but misses several that are closer.

of the ray. However, had it been continued it would eventually have found a second virtual listener located somewhat farther from the source. The second problem is illustrated by ray  $\beta$  which can be seen to slide past a number of closer virtual listeners before eventually hitting one near the periphery of the figure. Using the parameters for the ray trace shown in the figure, these closer VSs will never be found. It is important to realize that the solutions to these two problems conflict with each other. In order to solve the first we would like to reduce the size of the listener zone to minimize the size of its shadow. However, doing so will decrease the likelihood of a virtual listener's being found by a ray, exacerbating the second problem.

The image model limits its computation by rejecting virtual sources found to be too far from the listener. As a result, the image model is guaranteed to find all of the virtual sources within a certain radial distance of the listener. When the information concerning the sound paths is reduced to the impulse response, the two methods will produce different impulse responses. All of the reflections found by the ray tracing method will correspond exactly to reflections found by the image model, but the image model will also find a number of reflections that the ray tracing method missed, and in exchange, the ray tracing method will find a number of reflections outside the period being considered. Missing some of the sound paths will lead to an underestimate of the amount of sound energy in any period of the reverberant decay. Also, the effect of omitting these early echoes will usually be clearly audible in a simulation of the concert hall. It is possible to minimize the errors of the ray tracing method by choosing a very small listener zone, emitting a very large

number of rays, and then keeping only the shortest paths. The real problem is that there is no way to know whether a path has been missed. Missing even a single one can alter audible simulations. This limitation of ray tracing might also explain anomalies observed when it is used to analyze the properties of reverberation.<sup>8,9</sup>

There are many variants of the ray tracing technique described here, but they do not alter the final conclusion. For example, Wayman<sup>9</sup> and Walsh<sup>10</sup> assume the listener is a point, but the ray has cross section. It is also possible to terminate the extension of rays on the basis of their total length. Allowing rays to pass through listener zones renders them transparent. As transparent listener zones do not cast shadows, farther virtual listeners would not be lost behind closer ones. The penalty is unnecessary computation in cases where no virtual listeners were hiding. Although it might be possible to coerce the ray tracing method into providing accurate and complete information, it should be clear that the image model has the advantage of providing the desired information as a matter of course.

### E. Amount of computation required

In any practical application of the extended image model it is important to have a sense of how the complexity of the model influences the amount of computation required. A convenient measure of the amount of computation is the number of VSs computed,  $N_{vs}$ . Figure 14 shows empirical results for the variation in  $\log_{10} N_{vs}$  versus the truncation time  $t_{max}$  for three different concert hall geometries. In every case, the floor plan of the hall is a polygon and the cross

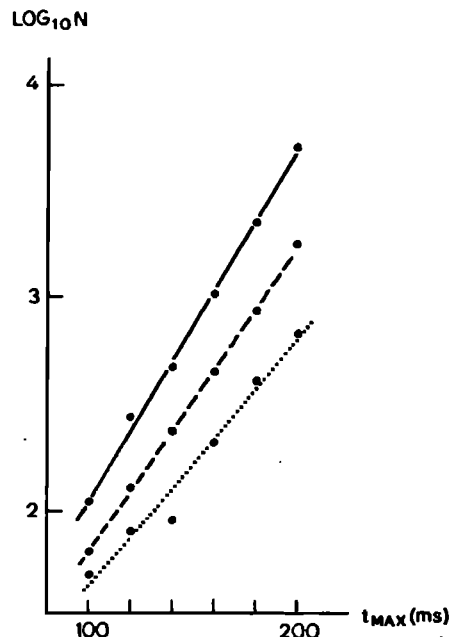

FIG. 14. Comparison of the amount of computation required by the extended image model for different geometries. The rooms all have the same volume and rectangular cross section, but the floor plans are polygons with different numbers of sides. (—) is for an octagonal plan, (---) is for a hexagonal plan, and (· · ·) is for a square. The approximate linearity of these traces indicates that the dependence is exponential, with a doubling in the number of VSs for an increase in  $t_{max}$  of 18, 21, and 26 ms, respectively.

section is rectangular. The volumes of the polyhedra were equalized to provide a consistent basis for comparison. As expected, the amount of computation increases as the number of sides increases. Somewhat unexpectedly, the dependence upon  $t_{\max}$  is almost perfectly exponential, with a doubling of  $N_{vs}$  for an increase in  $t_{\max}$  of 18–26 ms. We have found halls that produce a doubling of  $N_{vs}$  for as little as 10 ms. In such cases, one can easily initiate a computation that will require an inordinate amount of time. The adherence to an exponential law makes it possible to anticipate these situations by extrapolating from the values of  $N_{vs}$  for small  $t_{\max}$  to the value for the desired  $t_{\max}$ . An excessive value mandates simplification. Unfortunately, the number of sides in the polyhedron is not the only factor. Distorting the shape while maintaining the number of sides will affect the amount of computation in an unpredictable way. Even a change as simple as moving the source or listener can have a significant effect.

### III. CONCLUSION

The extension of the image model to complex shapes eliminates its most obvious limitation. The only geometrical restriction remaining is that the model of the concert hall must be piecewise planar. However, curved surfaces could be modeled using a piecewise planar approximation. The real limitation to the complexity of the shape is the computation time. By allowing the image model to deal with geometries more representative of those typically encountered in practice, it can be applied in a broader range of applications. The extended image model is the first step in creating audible simulations of concert halls. It also provides insight into the fundamental acoustical properties of familiar concert hall shapes. Because the images in the fan-shaped hall curve forward toward the front of the hall, the degree of spatial impression is reduced from what is obtainable in rectangular

halls. We found a geometry never applied in an actual concert hall design, the reverse fan, that would have an even greater spatial impression than rectangular halls.

### ACKNOWLEDGMENTS

This work was performed while the author was employed by Sound Technology, Campbell, CA. We would like to acknowledge the many useful discussions and suggestions provided by M. D. Ewy. The program that plots the positions of the VSs was written by Martin Vetterli. Thanks also to Dr. Angell, Dr. Schubert, and Dr. Chowning for all their support and assistance.

<sup>1</sup>V. O. Knudsen and C. M. Harris, *Acoustical Designing in Architecture* (American Institute of Physics, for the Acoustical Society of America, New York, 1978), Chap. 4, pp. 49–51.

<sup>2</sup>H. Kuttruff, *Room Acoustics* (Applied Science, London, 1973), Chap. 4, pp. 78–86.

<sup>3</sup>B. M. Gibbs and D. K. Jones, "A simple image method for calculating the distribution of sound pressure levels within an enclosure," *Acustica* 26, 24–32 (1972).

<sup>4</sup>J. B. Allen and D. A. Berkley, "Image method for efficiently simulating small-room acoustics," *J. Acoust. Soc. Am.* 65, 943–950 (1979).

<sup>5</sup>M. F. E. Barron, "The effects of early reflections on subjective acoustical quality in concert halls," Ph.D. thesis, University of Southampton (January 1974).

<sup>6</sup>D. E. Baxa and A. Seireg, "A strategy for the optimum design of acoustic space," *Trans. ASME/J. Mech. Des.* 100, 411–416 (July 1978).

<sup>7</sup>D. E. Knuth, *The Art of Computer Programming, Vol. 1/Fundamental Algorithms* (Addison-Wesley, Reading, MA, 1973), 2nd ed., Chap. 2, pp. 348–350.

<sup>8</sup>M. R. Schroeder, "Digital simulation of sound transmission in reverberant spaces (Part 1)," *J. Acoust. Soc. Am.* 47, 424–431 (1970).

<sup>9</sup>J. L. Wayman, "Computer simulation of sound fields using ray methods," Ph.D. thesis, University of California, Santa Barbara. (July 1980).

<sup>10</sup>J. P. Walsh and N. Dadoun, "The design and development of Godot: a system for computer-aided room acoustics modeling and simulation," *J. Acoust. Soc. Am. Suppl.* 1 69, S36 (1981).